

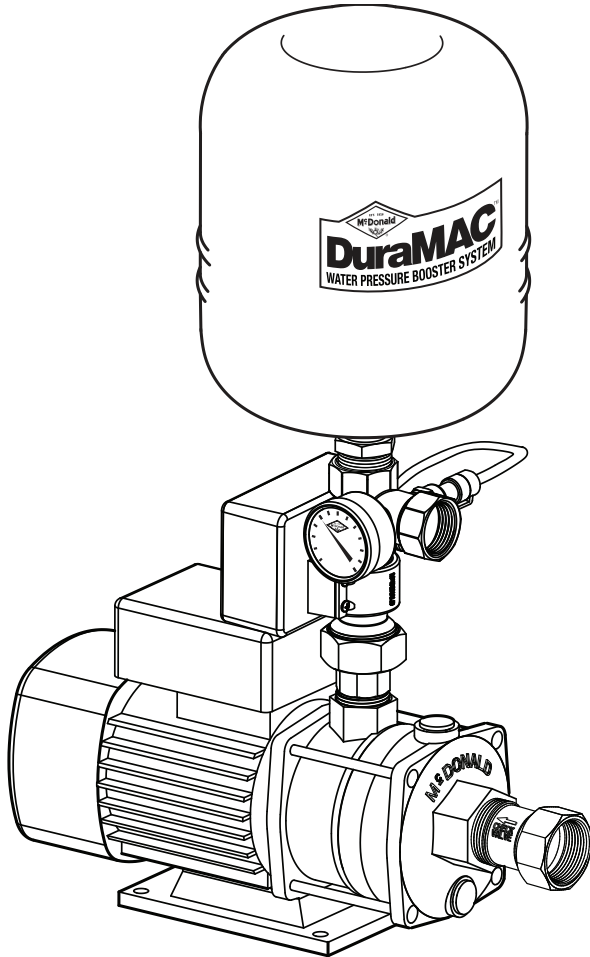

SPECIFICATIONS

DuraMAC™ Water Pressure Booster System

17040C035PC2, 17062C035PC2, 17078C035PC2
Water Pressure Booster Systems



Features

- Water Pressure Boosting System for irrigation or light commercial use
- Easy Set-up and Installation
- Digital Control with three modes of operation
- Durable Stainless Steel and No-Lead Brass Connections
- Two Gallon Pressure Tank
- TEFC Single Phase Motor for quiet operation
- Electronics separated and sealed from waterway
- Pressure Gauge Included
- No-Lead Brass Check Valve Included
- Dry-Run Protection

Materials of Construction

Impellers	304 Stainless Steel
Pump Casing Inlet	301 Stainless Steel
Pump Casing Outlet	301 Stainless Steel
Pump Seal (stationary)	Silicon Carbide
Pump Seal (rotating)	Carbon / NBR
Diffuser	304 Stainless Steel
Suction Check Valve	No-Lead Brass
Pump Controller	No-Lead Brass

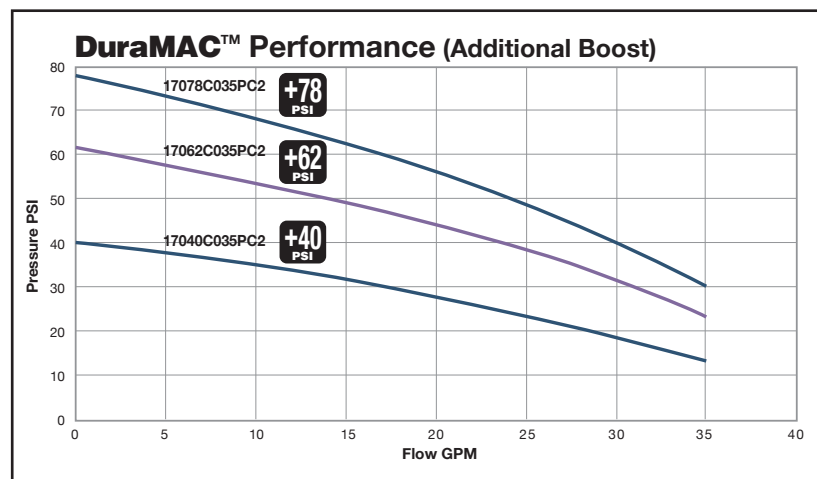

Specifications

DuraMAC™ Model	Pump Boost	Amps	Voltage	Power	*Maximum incoming pressure
17040C035PC2	40 psi	5.0	230 - 60 Hz	1 HP	40 psi
17062C035PC2	62 psi	6.3	230 - 60 Hz	1 HP	18 psi
17078C035PC2	78 psi	6.8	230 - 60 Hz	1½ HP	2 psi (for use with holding tank only)

Dimensional Information

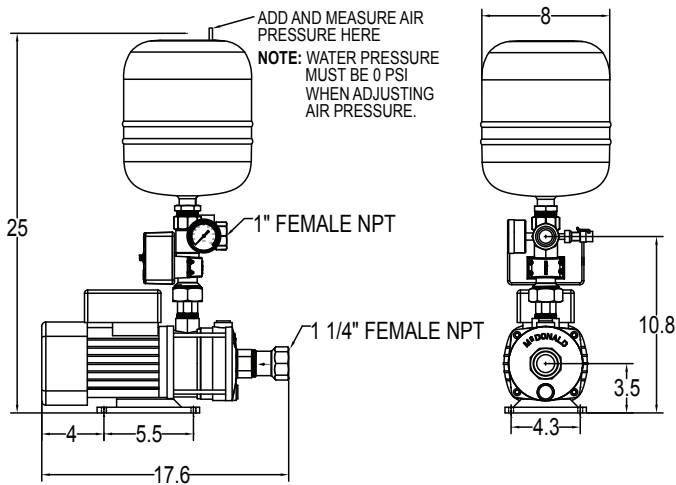

Sizing Chart

Total static pressure **DuraMAC™** pump

Incoming Pressure (PSI)	17040C035PC2 +40 PSI	17062C035PC2 +62 PSI	17078C035PC2 +78 PSI
60			
55			
50	90		
45	85		
40	80		
35	75		
30	70		
25	65	87	
20	60	82	
15	55	77	93
10	50	72	88

NOT RECOMMENDED

Typical Installation

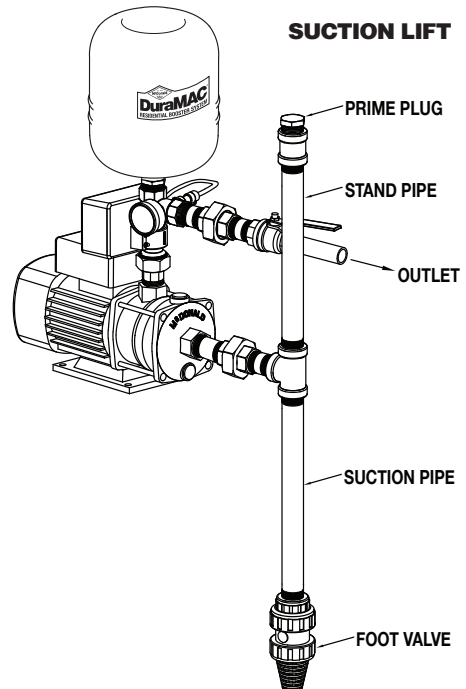
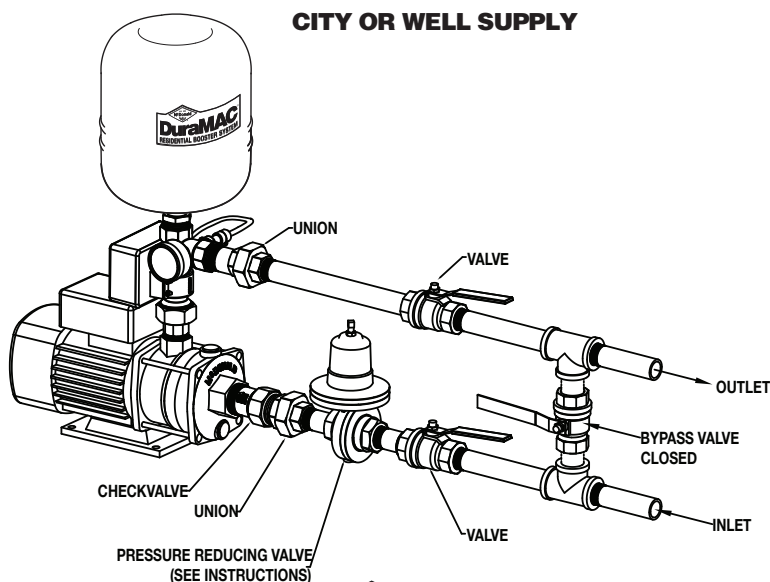

Sizing Information

DuraMAC™ Booster Systems are designed to shut off when no flow is detected. Pump total pressure boost should be added to current system pressure to determine total system pressure when boosted. Note: Many plumbing codes do not recommend system pressure exceeding 80 PSI. Refer to local plumbing codes for maximum boosted pressure.

Example:

Incoming system pressure before boost = 30 PSI

$$\begin{array}{r}
 \underline{30} \\
 \text{Incoming} \\
 \text{Pressure}
 \end{array}
 +
 \begin{array}{r}
 \underline{\quad} \\
 \text{Total Pump} \\
 \text{Pressure}
 \end{array}
 =
 \begin{array}{r}
 \underline{\quad} \\
 \text{Total Pressure} \\
 \text{After Boost}
 \end{array}$$

*Not Recommended to Exceed 80 PSI

Models Available: Boost

- 17040C035PC2 +40
- 17062C035PC2 +62
- 17078C035PC2 +78

$$\begin{array}{r}
 \underline{30} \\
 \text{Incoming} \\
 \text{Pressure}
 \end{array}
 +
 \begin{array}{r}
 \underline{40} \\
 \text{Total Pump} \\
 \text{Pressure}
 \end{array}
 =
 \begin{array}{r}
 \underline{70} \\
 \text{Total Pressure} \\
 \text{After Boost}
 \end{array}$$

Based on this example, the recommended model for this application is the 17040C035PC2.

For systems with fluctuating pressure, a pressure reducing valve is recommended to ensure system pressure stays below 80 PSI.



A. Y. McDonald Mfg. Co.

www.ayboosters.com • www.aymcdonald.com